

PLANNING DIMENSIONS

All dimensions in millimetres

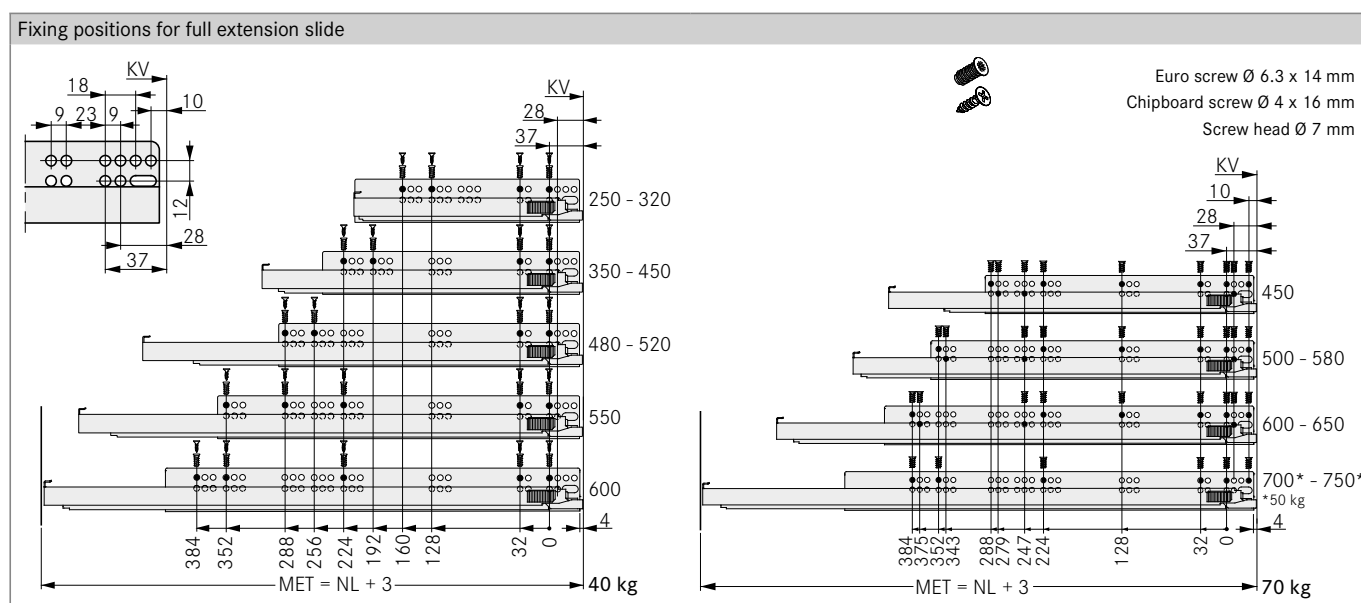
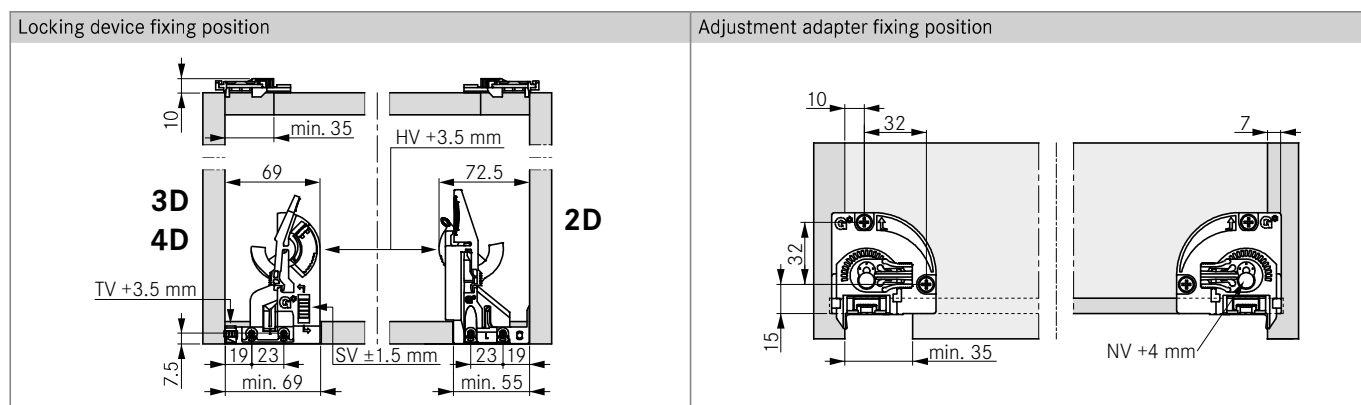
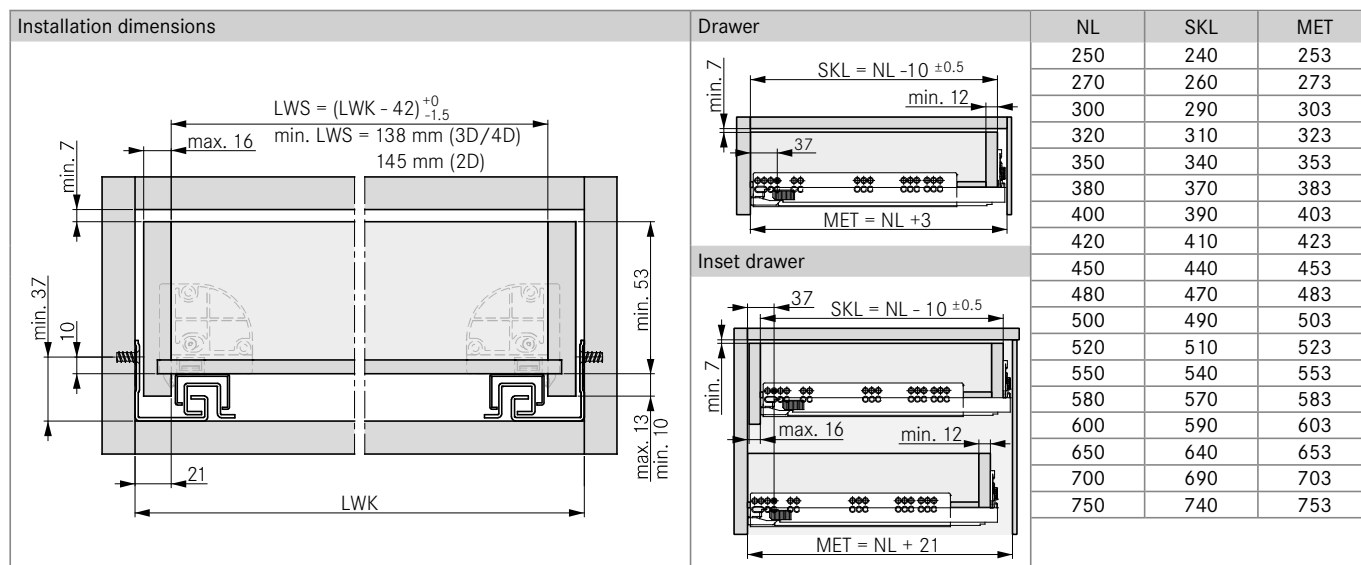

LEGEND

HV	Height adjustment	MET	Minimum installation depth	SV	Side adjustment
KV	Front edge of cabinet	NL	Nominal length	TV	Depth adjustment
LWK	Inside cabinet width	NV	Tilt angle adjustment		
LWS	Internal drawer width	SKL	Length of drawer		